

# PROVISIONES VARIAS

UPN 100

Refuerzos

MATERIAL: PEAD:1.00mm

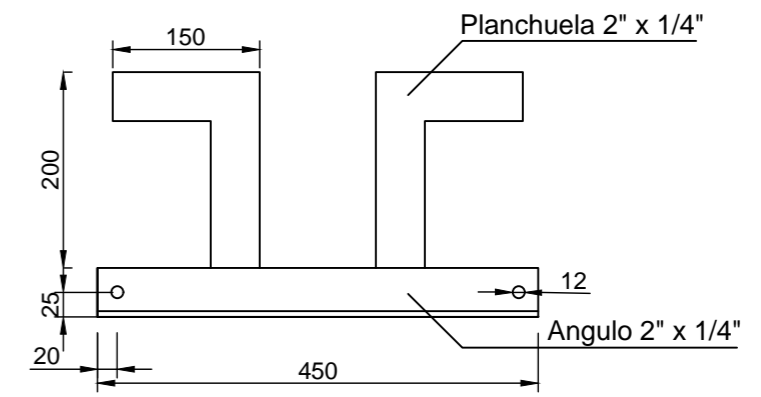
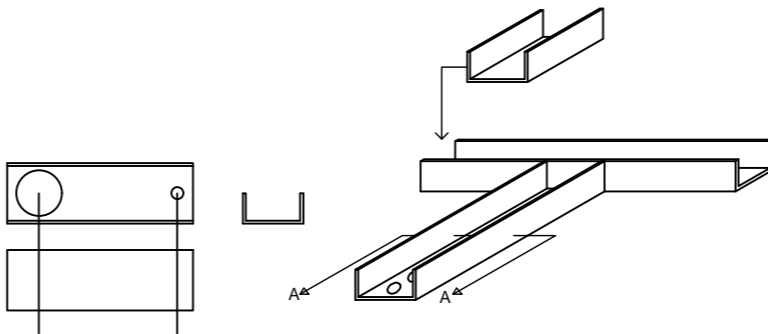
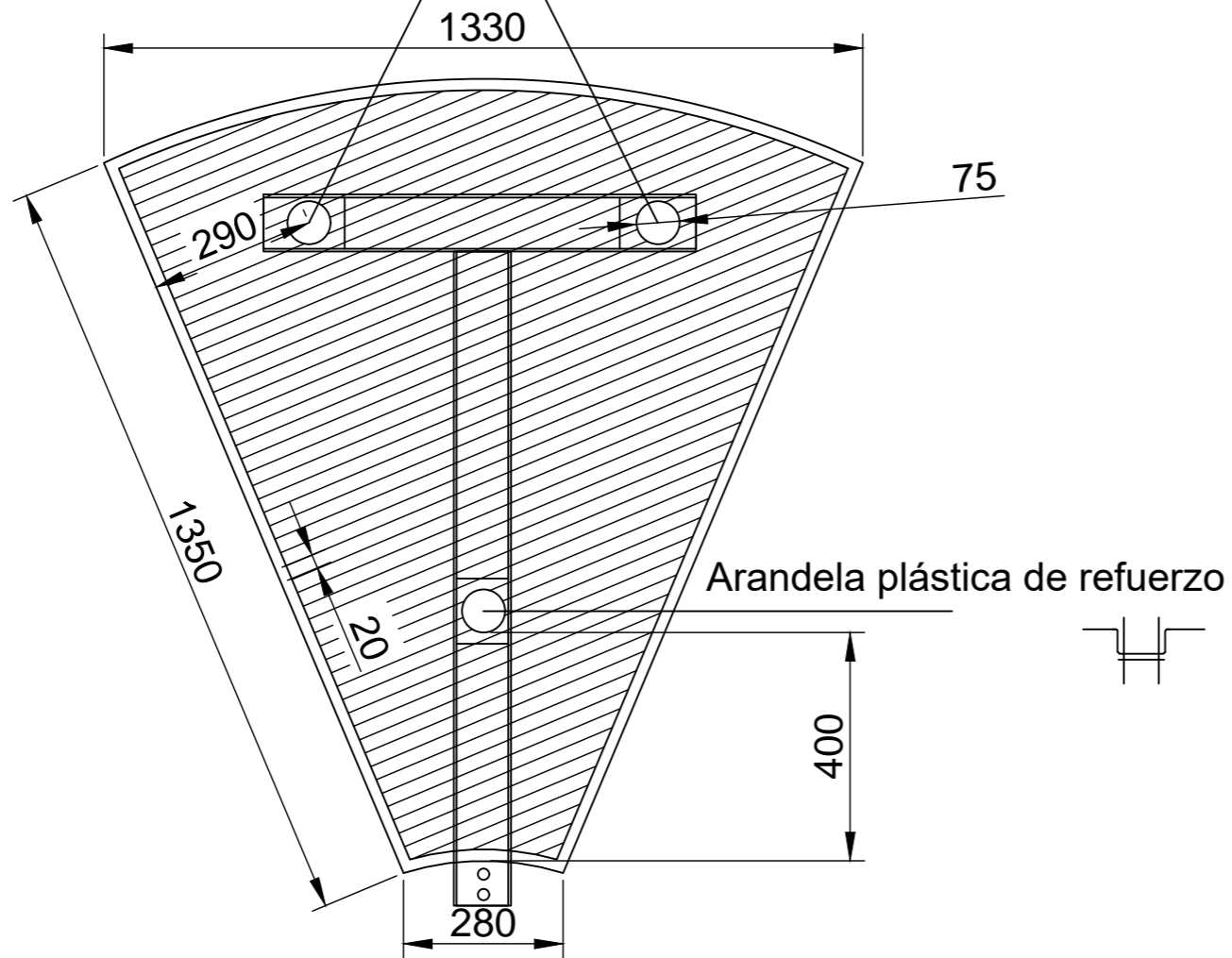

MATERIAL: Acero, SAE grado 8.

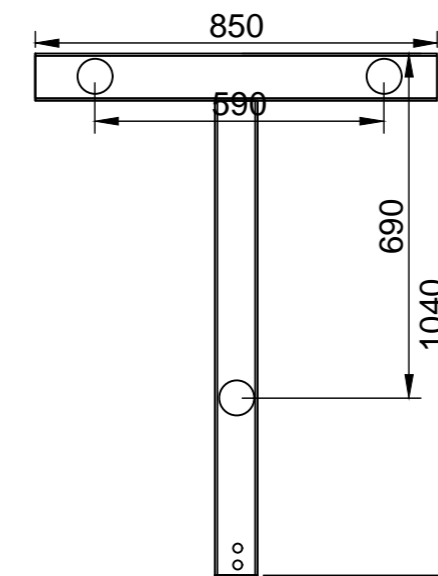
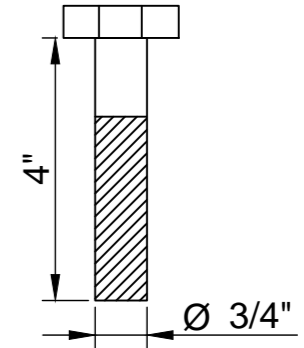

Abrazaderas.  
MATERIAL: Acero 1045

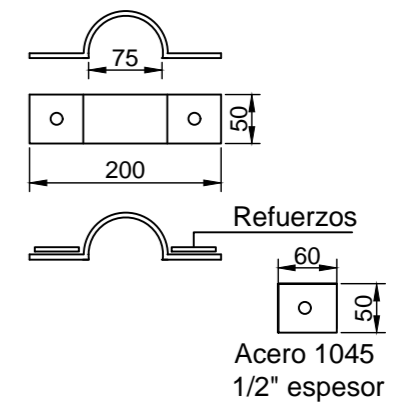

Ejes.

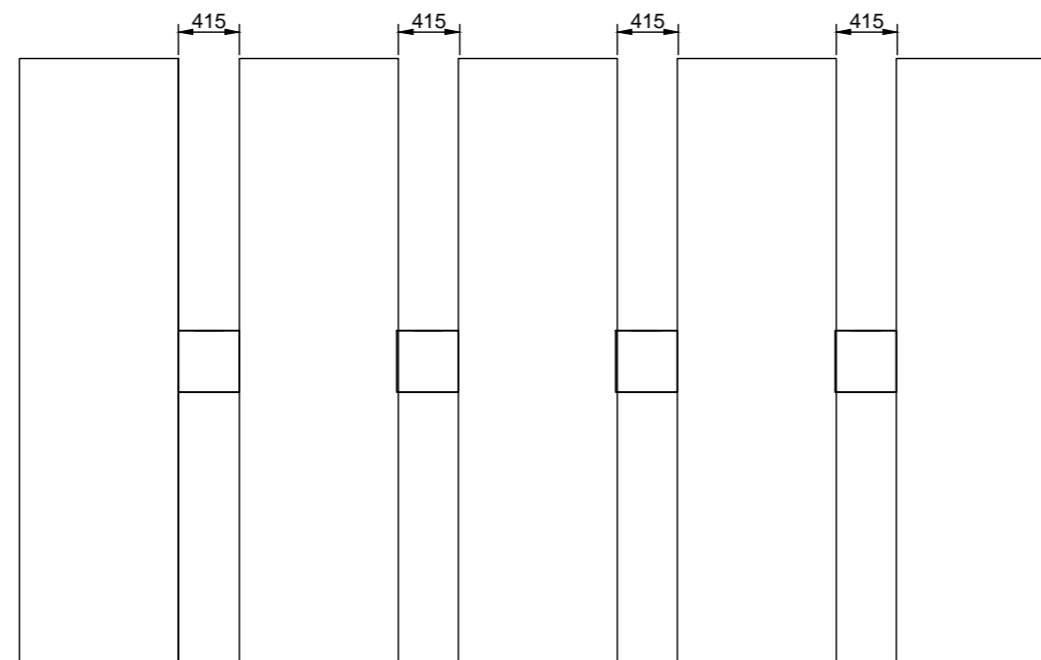
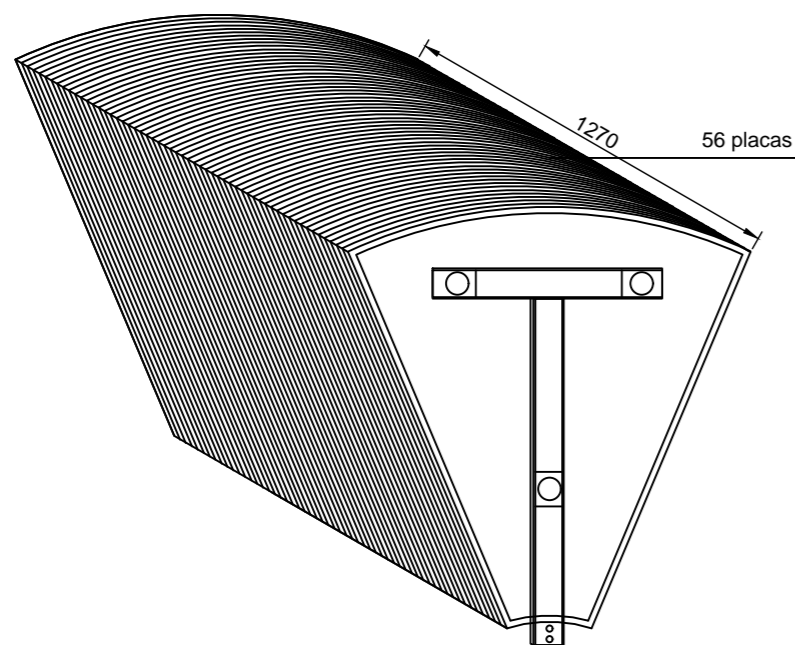
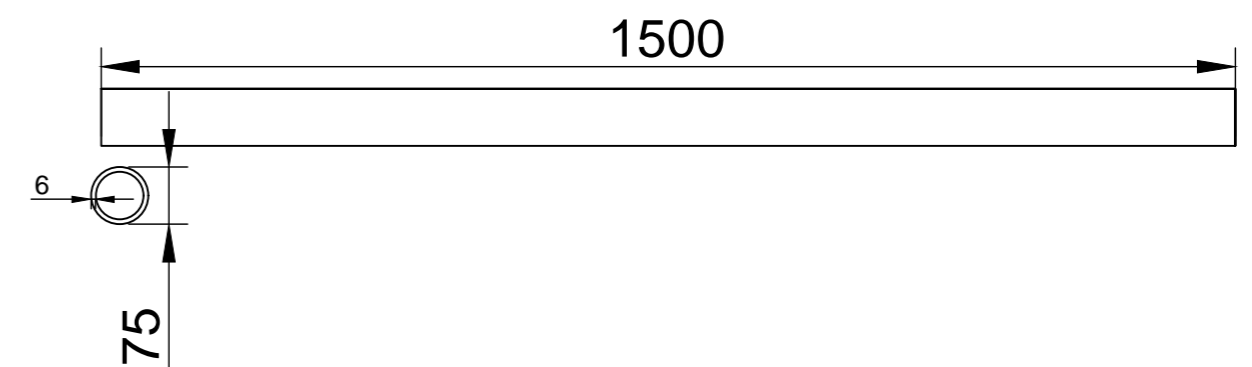

 <b>MUNICIPALIDAD DE TUPUNGATO</b>		INTENDENTE: GUSTAVO ADRIÁN SOTO.
		DIRECTOR DE OBRAS: Sr. MARCELO ELIZONDO.
OBRA: REPARACIÓN DE PLANTA DE TRATAMIENTO DE LÍQUIDOS CLOCALES		
PLANO: PROVISIONES VARIAS		
UBICACIÓN: CALLE MARCONI S/N		
PROYECTO: DIRECCIÓN GENERAL DE OBRAS PÚBLICAS.		
DIBUJO: DIRECCIÓN GENERAL DE OBRAS PÚBLICAS.	ESCALA: S/E	
COMPUTO: DIRECCIÓN GENERAL DE OBRAS PÚBLICAS.		